

WIRELESS MICROPHONE SYSTEM

User's Manual



INDEX

| | |
|---|--------------|
| 01 SAFETY RELATED SYMBOLS | 2 |
| 02 WARNING | 2 |
| 03 IMPORTANT SAFETY INSTRUCTIONS | 3 |
| 04 INTRODUCTION | 4 |
| 05 CONTROL ELEMENTS | 5~8 |
| 06 OPERATING INSTRUCTION | 9~11 |
| 07 TECHNICAL SPECIFICATIONS | 12-13 |

IMPORTANT!

Please read this manual carefully before operating this unit for the first time.

TECHNICAL SPECIFICATIONS

TRANSMITTER

| Specification \ MODEL | Beltpack transmitter | Handheld transmitter |
|------------------------|--|--|
| Carrier frequency band | UHF | UHF |
| Oscillation mode | PLL UHF SYNTHESIZED | PLL UHF SYNTHESIZED |
| Modulation mode | FM(F3E) | FM(F3E) |
| Frequency stability | ±0.005% | ±0.005% |
| RF RadiationFcc | 10mW | 10mW |
| RF Radiation CE | | |
| Spurious Emission | 45dBm ↓ | 45dBm ↓ |
| T.H.D | < 1.0% | < 1.0% |
| Frequency response | 50Hz-15KHz(±3dB) | 50Hz-15KHz(±3dB) |
| Current drain | < 150mA | < 150mA |
| Battery | "AA" typex2pcs (used for more than 6 hours) | "AA" typex2pcs (used for more than 6 hours) |
| Operating Temperature | -10°C to 50°C | -10°C to 50°C |
| Tone frequency | 32.768KHz | 32.768KHz |
| Dimensions | 65x85x25mm | 240* φ 50mm |
| Weight | 0.082Kg | 0.27Kg(Approx.) |
| Dynamic | > 100dB | > 100dB |
| Mic / Instrument Input | 10dBu | 10dBu |
| Microphone Capsule | Condenser Dynamic Capsule | Dynamic Capsule |
| 4 band choice | 1. Ground | / |
| | 2. Power supply | |
| | 3. Electric instrument | |
| | 4. Dynamic or condenser Mic | |

SAFETY RELATED SYMBOLS



The symbol is used to indicate that some hazardous live terminals are involved within this apparatus, even under the normal operating conditions.



The symbol is used in the service documentation to indicate that specific component shall be only replaced by the component specified in that Documentation for safety reasons.



Protective grounding terminal.



Alternating current /voltage.



Hazardous live terminal .

ON: Denotes the apparatus turns on.

OFF: Denotes the apparatus turns off, because of using the single pole switch, be sure to unplug the AC power to prevent any electric shock before you proceed your service.

WARNING: Describes precautions that should be observed to prevent the danger of injury or death to the user.



Disposing of this product should not be placed in municipal waste and should be separate collection.

CAUTION: Describes precautions that should be observed to prevent danger of the apparatus.

WARNING

• Power Supply

Ensure the source voltage matches the voltage of the power supply before turning ON the apparatus.

Unplug this apparatus during lightning storms or when unused for long periods of time.

• External Connection

The external wiring connected to the output hazardous live terminals requires installation by an instructed person, or the use of ready-made leads or cords.

• Do not Remove any Cover

There are maybe some areas with high voltages inside, to reduce the risk of electric shock, do not remove any cover if the power supply is connected.

The cover should be removed by the qualified personnel only.

No user serviceable parts inside.

• Fuse

To prevent a fire, make sure to use fuses with specified standard (current, voltage, type). Do not use a different fuse or short circuit the fuse holder.

Before replacing the fuse, turn OFF the apparatus and disconnected the power source.

• Protective Grounding

Make sure to connect the protective grounding to prevent any electric shock before turning ON the apparatus.

Never cut off the internal or external protective grounding wire or disconnect the wiring of protective grounding terminal.

• Operating Conditions

This apparatus shall not be exposed to dripping or splashing and that no objects filled with liquids, such as vases, shall be placed on this apparatus.

To reduce the risk of fire or electric shock, do not expose this apparatus to rain or moisture.

Do not use this apparatus near water. Install in accordance with the manufacture-r's instructions. Do not install near any heat sources such as radiators, heat registers, stoves, or other apparatus (including amplifiers) that produce heat. Do not block any ventilation openings.

No naked flame sources, such as lighted candles, should be placed on the apparatus.

IMPORTANT SAFETY INSTRUCTIONS

- Read these instructions.
- Follow all instructions.
- Keep these instructions.
- Heed all warnings.
- Only use attachments/accessories specified by the manufacturer.

• Power Cord and Plug

Do not defeat the safety purpose of the polarized or grounding type plug.

A polarized plug has two blades with one wider than the other. A grounding type plug has two blades and a third grounding prong. The wide blade or the third prong are provided for your safety. If the provided plug does not fit into your outlet, consult an electrician for replacement of the obsolete outlet.

Protect the power cord from being walked on or pinched particularly at plugs, convenience receptacles, and the point where they exit from the apparatus.

• Cleaning

When the apparatus needs a cleaning, you can blow off dust from the apparatus with

a blower or clean with rag etc.

Don't use solvents such as benzol, alcohol, or other fluids with very strong volatility and flammability for cleaning the apparatus body. Clean only with dry cloth.

• Servicing

Refer all servicing to qualified personnel. To reduce the risk of electric shock, do not perform any servicing other than that contained in the operating instructions unless you are qualified to do so .

Servicing is required when the apparatus has been damaged in any way , such as power supply cord or plug is damaged , liquid has been spilled or objects have fallen into the apparatus, the apparatus has been exposed to rain or moisture , does not operate normally, or has been dropped.

The mains plug is used as the disconnect device, the disconnect device shall remain readily operable.

Changes or modifications to this unit not expressly approved by the party responsible for compliance could void the user's authority to operate the equipment.

FCC Rules and Regulations

MARKUS wireless receivers are certified under FCC Rules part 15 and transmitters are certified under FCC Rules part 74.Licensing of MARKUS equipment is the user's responsibility and licensability depends on the user's classification, application and frequency selected.

NOTE: This equipment has been tested and found to comply with the limits for a class B digital device, pursuant to Part 15 of the FCC Rules .These limits are designed to provide reasonable protection against harmful interference in a residential installation . This equipment generates, uses and can radiate radio frequency energy and , if not installed

OPERATING INSTRUCTION

Turn on your connected amplifier or mixer, but keep the volume all the way down. Set the Volume knob on the receiver fully clockwise.This is unity gain.

Speak or sing into the microphone,or if you are using the transmitter with a connected instrument,play the instrument at normal performance level. Slowly raise the volume of your amplifier or mixer until the desired level is reached.

If you find the system has noticeable dropouts,reduced overall working range,or unexpected noise bursts, change the operating channel of the system using the steps above.

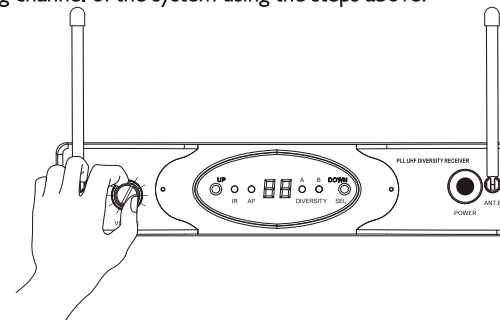

TECHNICAL SPECIFICATIONS

RECEIVER

| | |
|-----------------------|---|
| Channel | Single-channels,up to 99 frequency presets for each frequency bands |
| Receiver type | Single Receiver |
| Receiver type | PLL UHF SYNTHESIZED |
| Frequency band | UHF |
| Frequency response | 50Hz-15KHz(±3dB) |
| Frequency stability | ±0.005% |
| Modulation mode | FM(F3E) |
| T.H.D | < 1% |
| Dynamic | > 100dB |
| Max Unbalanced Output | 10dBu |
| Max Balanced Output | 0dBu |
| S/N Ratio | >100 dB |
| RF sensitivity | -100dbm/30db sinad |
| Power supply | DC 15V/300mA |
| Dimensions | 220(W)×125(H)×45(L) mm |
| Weight | 0.56Kg(Approx.) |

OPERATING INSTRUCTION

Position the transmitter about 15~30cm from the front of the receiver with the transmitter's IR window facing the IR transmitter on the front panel of the receiver.

Press and hold the receiver UP/DOWN button to set the transmitter to the same channel as the receiver via infrared transmission.

When the transmission is complete, the receiver will receive RF signal and tone key from the transmitter. The A/B indicator will light on the front panel of the receiver.

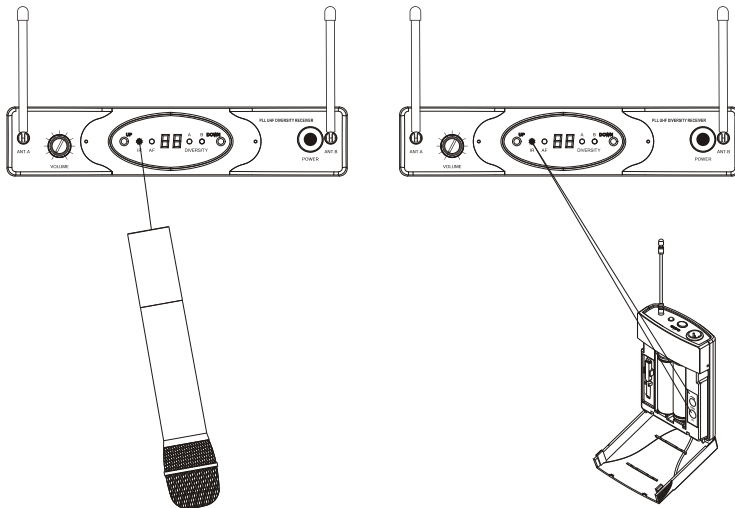
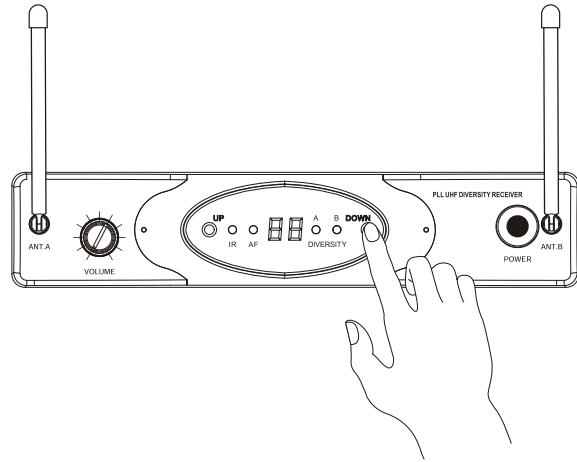

and used in accordance with the instructions, may cause harmful interference to radio communications. However, there is no guarantee that interference will not occur in a particular installation. If this equipment does cause harmful interference to radio or television reception, which can be determined by turning the equipment off and on, the user is encouraged to try to correct the interference by one or more of the following measures:

- Reorient or relocate the receiving antenna.
- Increase the separation between the equipment and receiver.
- Connect the equipment into an outlet on a circuit different from that to which the receiver is connected.
- Consult the dealer or an experienced radio/TV technician for help.

This device complies with Part 15 of the FCC Rules. Operation is subject to the following two conditions:(1) this device may not cause harmful interference and (2) this device must accept any interference received, including interference that may cause undesired operation.

Hereby, Seikaku Technical Group Limited, declares that this wireless microphone system is in compliance with the essential requirements And other relevant provisions of Directive 1999/5/EC.

INTRODUCTION

Thanks for purchasing the wireless microphone system. The system is the delicately designed UHF, PLL synthesized system, with antenna for smart switching diversity control, the higher level RF signals maybe fed into the system for greater reliability and coverage, therefore, the risks of break down and interference are to be effectively reduced.

The system features as follows:

- Switching diversity control to receive the RF signal;
- LED indication for RF, AF and POWER;
- PLL synthesized design, 100 channel frequency presets;
- Consistent operating frequencies to comply with the EMC regulations;
- Transmitter battery: Two 1.5V, convenience Operation.
- The balance and the un-balanced audio output, connect each kind of acoustic equipment easily.

CONTROL ELEMENTS

RECEIVER FRONT PANEL

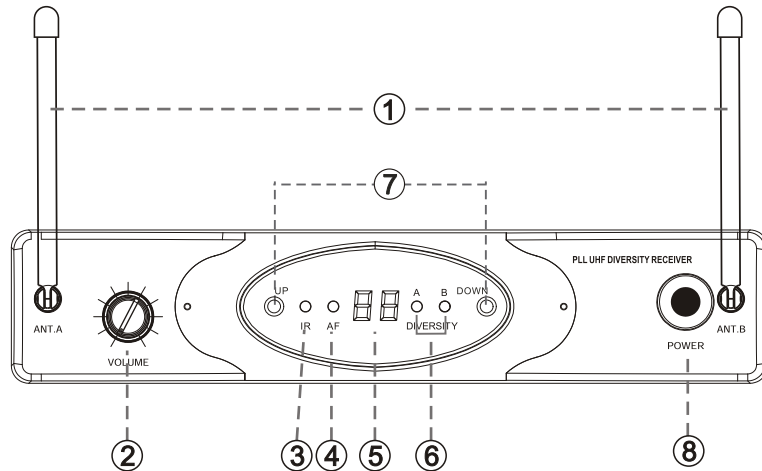

① **ANT-A & ANT-B**

It is the flexible antenna. To get effective transmission, never cover the antenna with hand, clothes, etc during the operation, and always position the transmitter nearby the receiver.

② **VOLUME Control**

This knob sets the audio signal level outputted through the balanced and unbalanced output jacks on the rear panel. Turn the knob clockwise fully for the max volume, and turn the knob counterclockwise fully for the min volume.

③ **IR Transmitting Section**

During 'IR SET' an infrared light is used to set the transmitter channel.

④ **AF**

When this LED is illuminating, it means that the signal of the microphone is too strong.

⑤ **Display**

This sexy and smart display will show exact Channel selected from 00~99, totally 100 channels.

⑥ **Diversity LED A & B**

These two LED will light up when the ANT-A & ANT-B are used.

OPERATING INSTRUCTION

With the transmitter powered off, install two fresh AA batteries into the transmitter.

Leave the battery compartment open.

Turn on the power to the transmitter by pressing and holding Power switch; the indicator LED will light green.

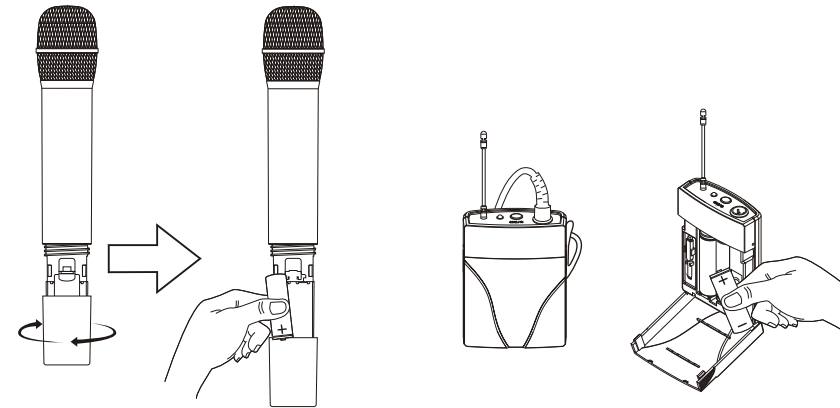

Press the UP/DOWN button on the front of the receiver to choose an available channel.

The channel number will increase by two digit, from 00-99. Once the last channel has been reached, the count will cycle back to 00.

Press and hold the UP/DOWN button for 2 seconds to send the channel information to the transmitter via infrared transmission.

Press and hold the UP button the display channel will be fast forward.

Press and hold the DOWN button the display channel will be fast backward.

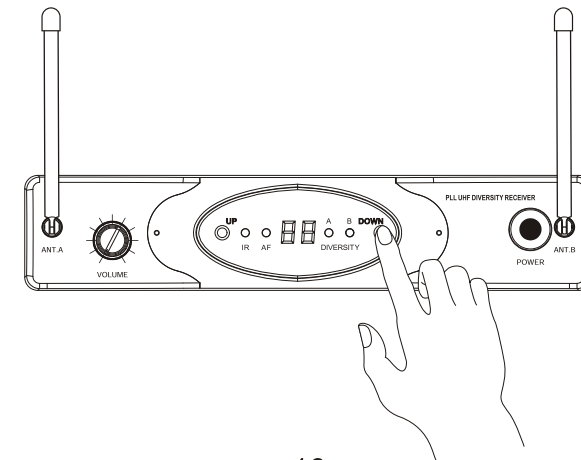

OPERATING INSTRUCTION

In order for your wireless system to work correctly, both the receiver and transmitter must be set to the same channel.

Follow the basic procedure for setting up and using your the wireless system:

Physically place the receiver where it will be used, and extend the antennas vertically. With the Power switch on and receiver power off, connect the included power adapter. Turn the receiver on momentarily to confirm that the unit is receiving power. You will see the LED display light up. Then turn receiver power off.

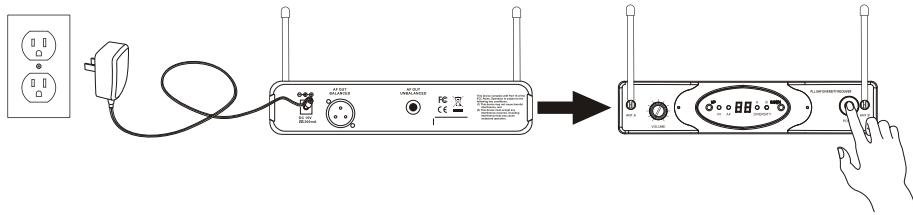

With your amplifier or mixer off and volume control all the way down: connect the receiver output jack to the mic or line level input of a mixer or amplifier using the balanced XLR output or unbalanced 1/4" line level output. Turn the Level knob on the receiver completely counterclockwise, then turn its power on.

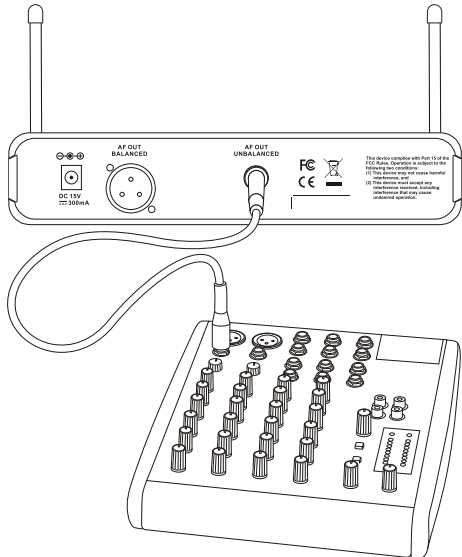

CONTROL ELEMENTS

⑦ UP/DOWN

Operation button.

⑧ Power Switch

It switches on/off the main power.

REAR PANEL

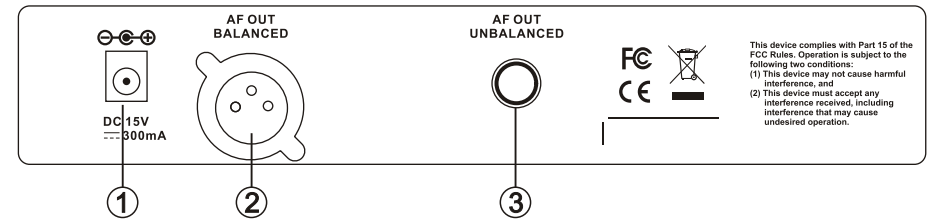

① DC Input

Connect the unit with the adapter for DC power supply. Refer to Fig 1.

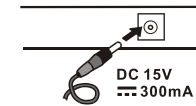

Fig 1

② AF OUT BALANCED

XLR type connector outputs the balanced AF signal.

③ AF OUT UNBALANCED

TS type jack outputs the unbalanced AF signal.

CONTROL ELEMENTS

HANDHELD TRANSMITTER

① Grille Holder

② Tube

③ Tail tube

④ Status Indicator

This LED displays the operation mode:

| | |
|--------------|------------------|
| GREEN | Normal Operation |
| RED | Mute |
| Flashing RED | Low Battery |

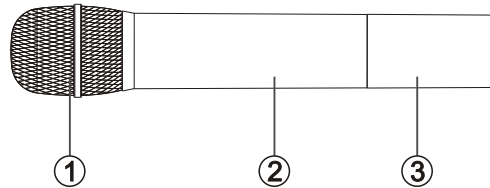

⑤ Power/Mute Switch

Press and hold to turn the unit on or off. Press and release to mute or unmute the transmitter.

⑥ IR Receiving Section

This window is used to capture the infrared signal sent from the receiver during the IR SET to channelize the transmitter.

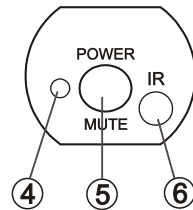

BELTPACK TRANSMITTER

① Antenna

This permanently attached transmitter antenna should be fully extended during normal operation.

② Status Indicator

This LED displays the operation mode:

| | |
|--------------|------------------|
| GREEN | Normal Operation |
| RED | Mute |
| Flashing RED | Low Battery |

③ Power/Mute Switch

Press and hold to turn the unit on or off. Press and release to mute or unmute the transmitter.

CONTROL ELEMENTS

④ MINI 4P CONNECTOR

Ⓐ Pin 1, GND

Ⓑ Pin 2, Phantom power supply for Condenser microphone

Ⓒ Pin 3, for Guitar, bass and keyboards

Ⓓ Pin 4, for Dynamic or condenser microphone

⑤ IR Receiving Section

This window is used to capture the infrared signal sent from the receiver during the IR SET to channelize the transmitter.

⑥ Input GAIN Control

This control adjusts the transmitter input sensitivity to work with microphone and instruments inputs. For optimal performance, using the included screwdriver, set the input GAIN control to where you see receiver PEAK indicator start to light under high levels, then turn down slowly until the PEAK light stops lighting.

⑦ Driver

Designed for use in adjusting the transmitter input GAIN control.

